

# Technical data sheet



## Product features

### Fry Top Griddle 97x48 electric durable chrome combined table 400 v

<b>Model</b>	<b>SAP Code</b>	00021118
--------------	-----------------	----------



- Top type: Combined
- Griddle dimensions [mm x mm]: 970 x 480
- Griddle thickness [mm]: 10.00
- Worktop material: Chrome plated steel
- Container for liquid fat: Yes
- Independent heating zones: Separate control for each heating zone
- Maximum device temperature [°C]: 300
- Surface finish: durable chrome
- Removable rim: No

<b>SAP Code</b>	00021118	<b>Power electric [kW]</b>	9.000
<b>Net Width [mm]</b>	991	<b>Loading</b>	400 V / 3N - 50 Hz
<b>Net Depth [mm]</b>	541	<b>Griddle dimensions [mm x mm]</b>	970 x 480
<b>Net Height [mm]</b>	288	<b>Top type</b>	Combined
<b>Net Weight [kg]</b>	73.00		

# Technical data sheet



Technical drawing

Fry Top Griddle 97x48 electric durable chrome combined table 400 v

Model	SAP Code	00021118
-------	----------	----------

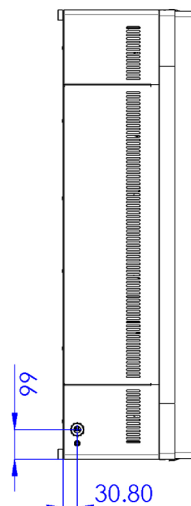
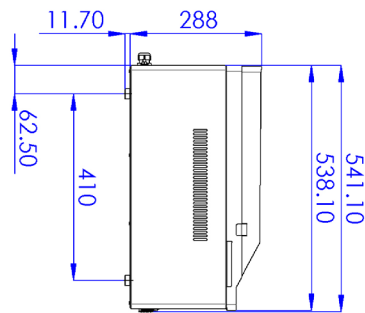
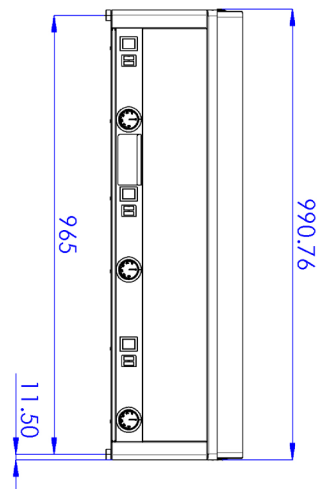

# Technical data sheet



## Product benefits

### Fry Top Griddle 97x48 electric durable chrome combined table 400 v

Model

SAP Code

00021118

1

#### **Nationheres**

long life  
stainless steel resistance of AISI 304  
the material does not rue

- Savings on service interventions
- easy and faster service

2

#### **Degree of protection of controls IPX4**

maintenance -free  
water resistance  
long life

- Savings on service interventions
- easy cleaning of the device

3

#### **Waste fluid socket**

ensures oil dripping into a socket

- easy maintenance
- easy to clean

4

#### **Tall non -removable hem**

Better Hygienic Conditions  
Preventing fat spraying on a secondary device

- easy maintenance
- easy to clean

5

#### **Combined plate made of chrome steel**

The product is less baked  
Allows preparation for smooth or grooved plate

- saving time when preparing meals
- Easy to prepare different types of dishes

6

#### **A kernel for use on a table or on a bedding**

variable use  
Possibility to place in smaller spaces

- easy manipulation
- saving costs on the bedding

# Technical data sheet



## Technical parameters

### Fry Top Griddle 97x48 electric durable chrome combined table 400 v

**Model**

**SAP Code**

00021118

**1. SAP Code:**

00021118

**2. Article group:**

Frying plates

**3. Net Width [mm]:**

991

**4. Net Depth [mm]:**

541

**5. Net Height [mm]:**

288

**6. Net Weight [kg]:**

73.00

**7. Gross Width [mm]:**

705

**8. Gross depth [mm]:**

1055

**9. Gross Height [mm]:**

540

**10. Gross Weight [kg]:**

80.00

**11. Device type:**

Electric unit

**12. Construction type of device:**

Table top

**13. Power electric [kW]:**

9.000

**14. Loading:**

400 V / 3N - 50 Hz

**15. Protection of controls:**

IPX4

**16. Material:**

AISI 430

**17. Indicators:**

operation and warm-up

**18. Worktop material:**

Chrome plated steel

**19. Surface finish:**

durable chrome

**20. Maximum device temperature [°C]:**

300

**21. Minimum device temperature [°C]:**

50

**22. Adjustable feet:**

Yes

**23. Griddle dimensions [mm x mm]:**

970 x 480

**24. Griddle thickness [mm]:**

10.00

**25. Container for liquid fat:**

Yes

**26. Independent heating zones:**

Separate control for each heating zone

**27. Removable rim:**

No

**28. Uniform heating:**

Yes

# Technical data sheet



Technical parameters

Fry Top Griddle 97x48 electric durable chrome combined table 400 v

<b>Model</b>	<b>SAP Code</b>	00021118
--------------	-----------------	----------

## 29. Top type:

Combinated